

ACARP Project C4033

Stimulation of Gas Make
from Horizontal In-Seam Drain Holes
by Hydraulic Fracturing

Completed December 1999

Method of placing hydraulic fractures in horizontal holes

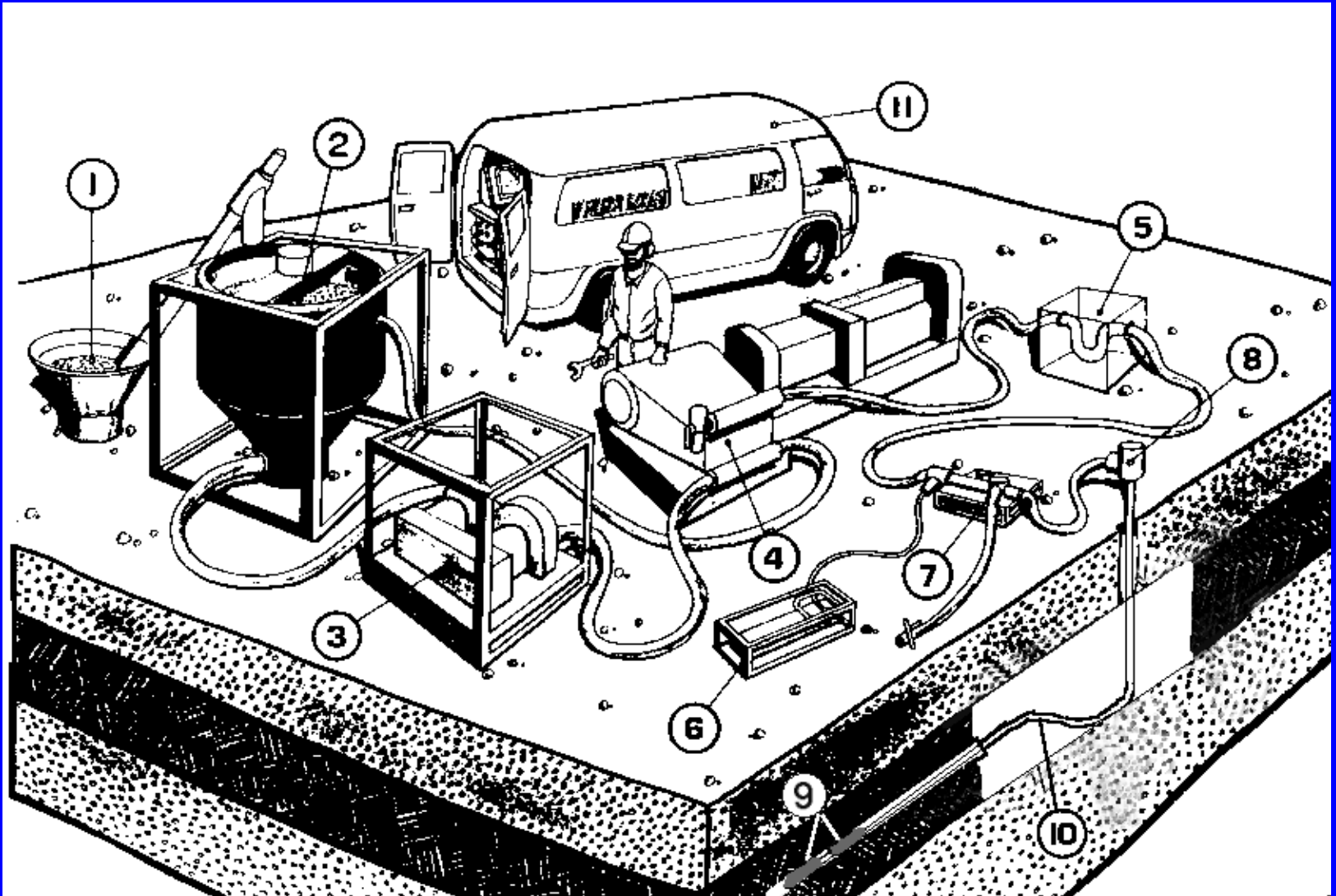

Trial site at
Central Colliery
LW 307.

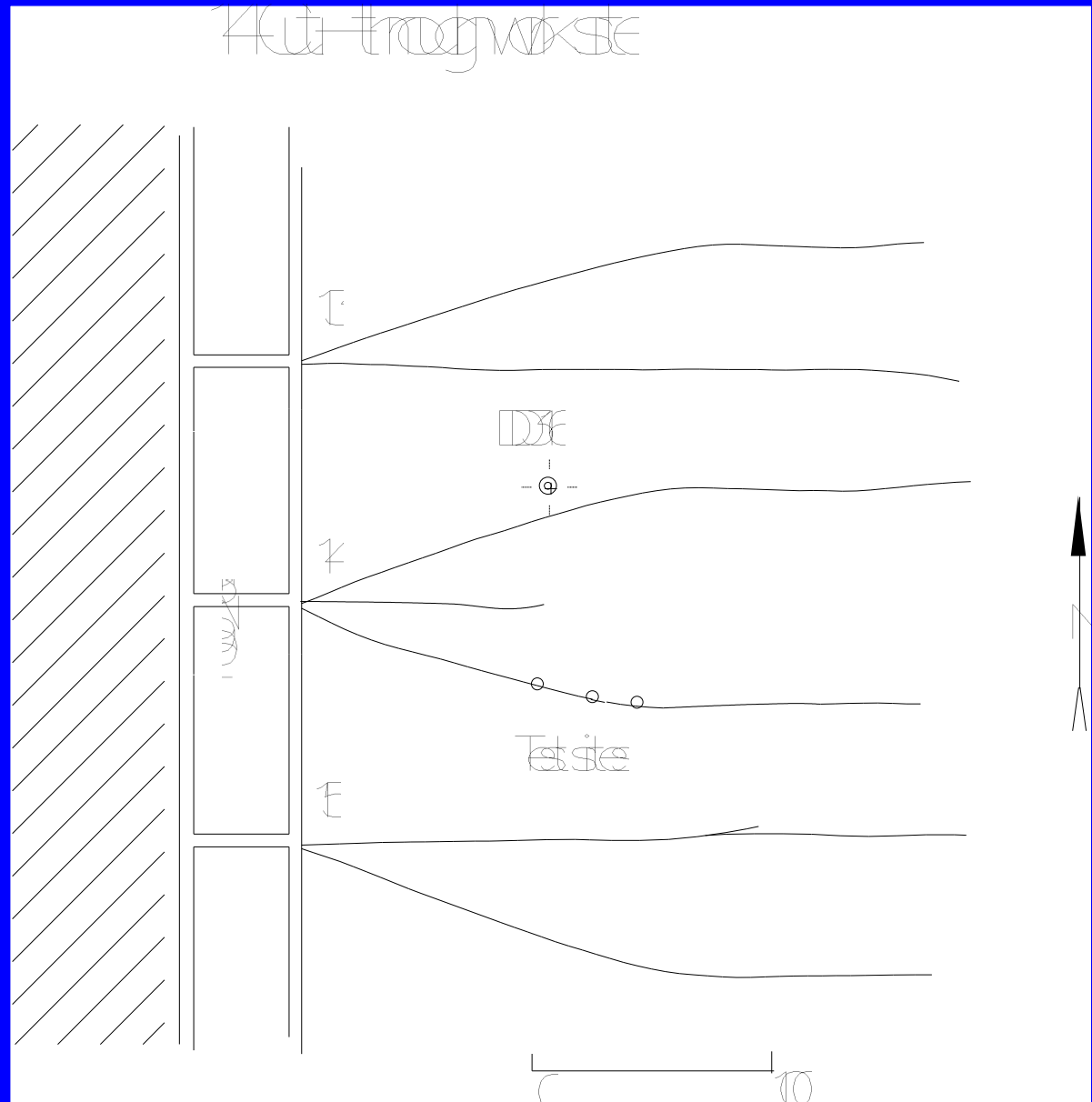

Stresses measured in DD 316

Depth (meters)	Description	σ_{h3} (MPa)	σ_{h1} (MPa)	σ_v (MPa)	Orient. Φ_{h1}	Comment
267.94- 268.65	Test S4. siltstone/ claystone	7.1	12.7	6.4	N24E grid	Vertical fracture running under packers.
269.38- 270.09	Test S3 sandstone	6.0	11.1	6.5	N18E grid	Vertical fracture.
275.5- 278.0	German Cr. coal seam	2.5- 3.0	--	6.6	--	Extension pressure 3.5 MPa
280.51- 281.22	Test S2 siltstone	7.7	12.8	6.7	N22E grid	Inclined sub- vertical fracture with horiz branches.
282.21- 282.92	Test S1 siltstone/ claystone	--	--	6.8	--	Horizontal fracture (coal parting) at packer.

Injection well test in DD 316

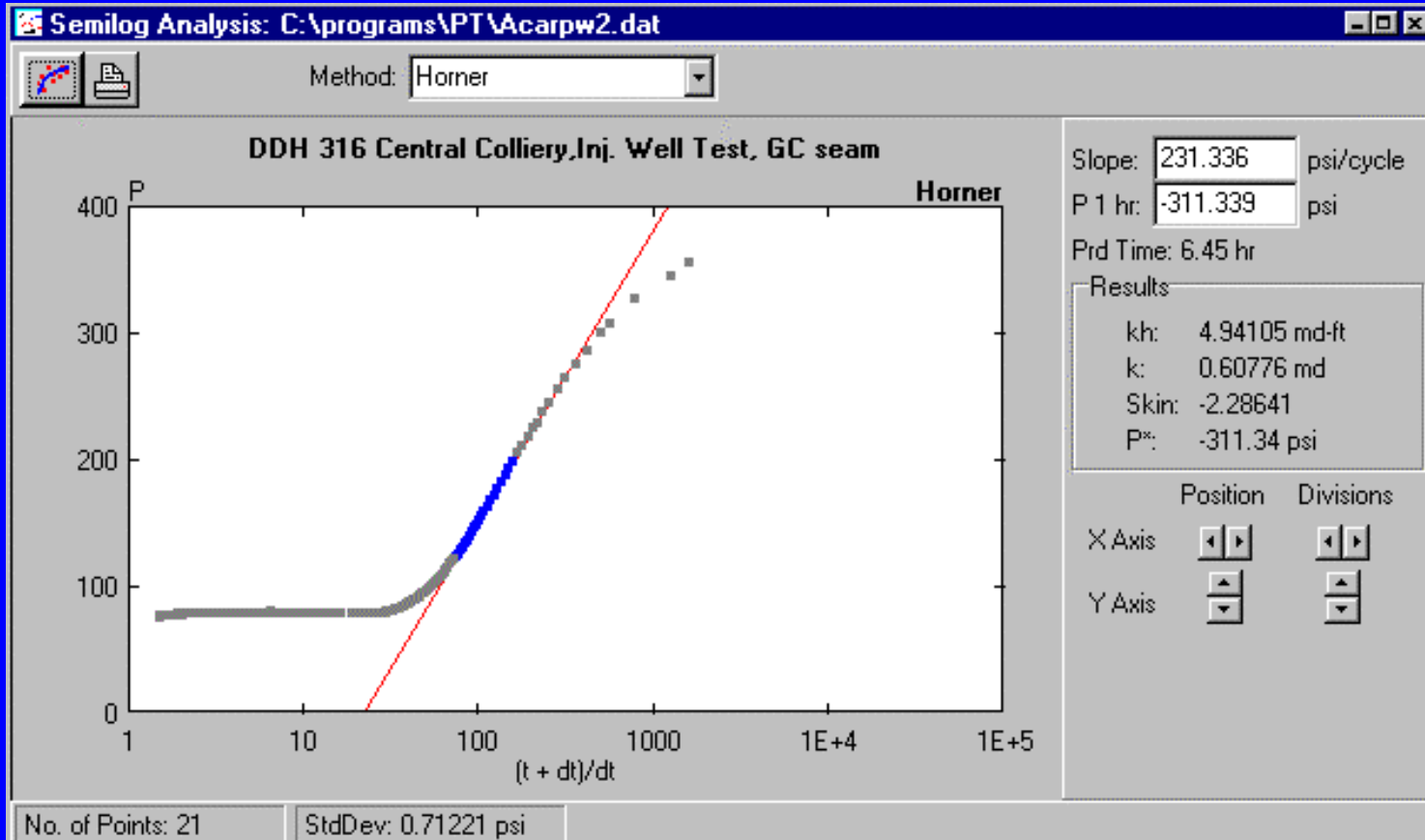

Piezometer data and calculated gas content

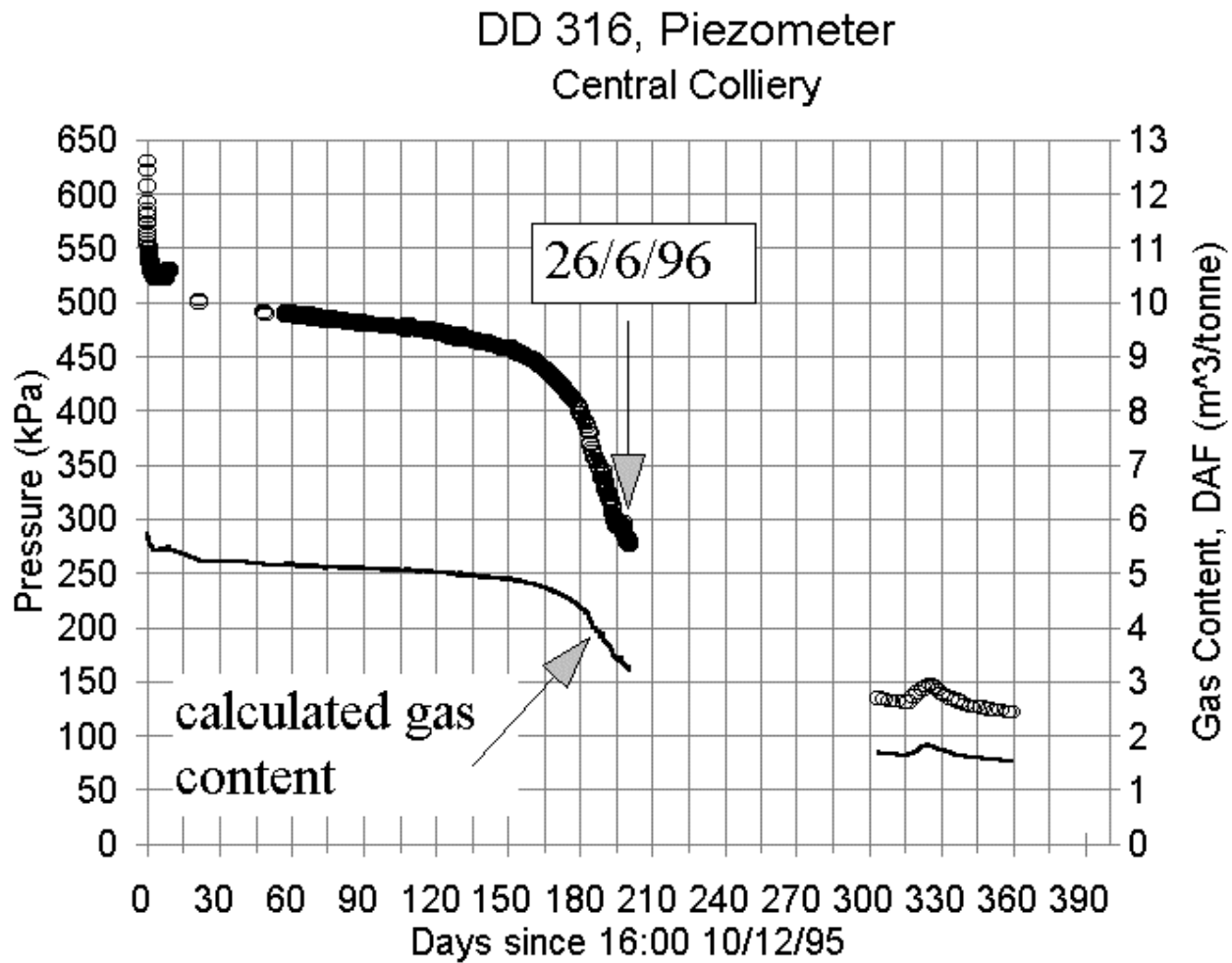

$$\begin{aligned}\text{Sigma} &= 3 \times \text{SH} - 1 \times \text{Sv} \\ &= 4 \text{ to } 5.5 \text{ MPa}\end{aligned}$$

Sigma H
(3.5 to 4 MPa)

An axial fracture will start when the borehole (packer) pressure is 4 to 5.5 MPa

Sigma V
6.5 MPa

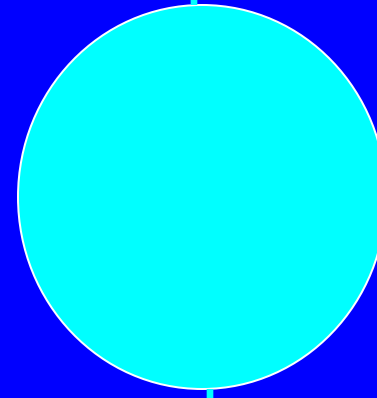

Pressure, injection rate and packer pressure during Injection at 117 m in horizontal drain hole.

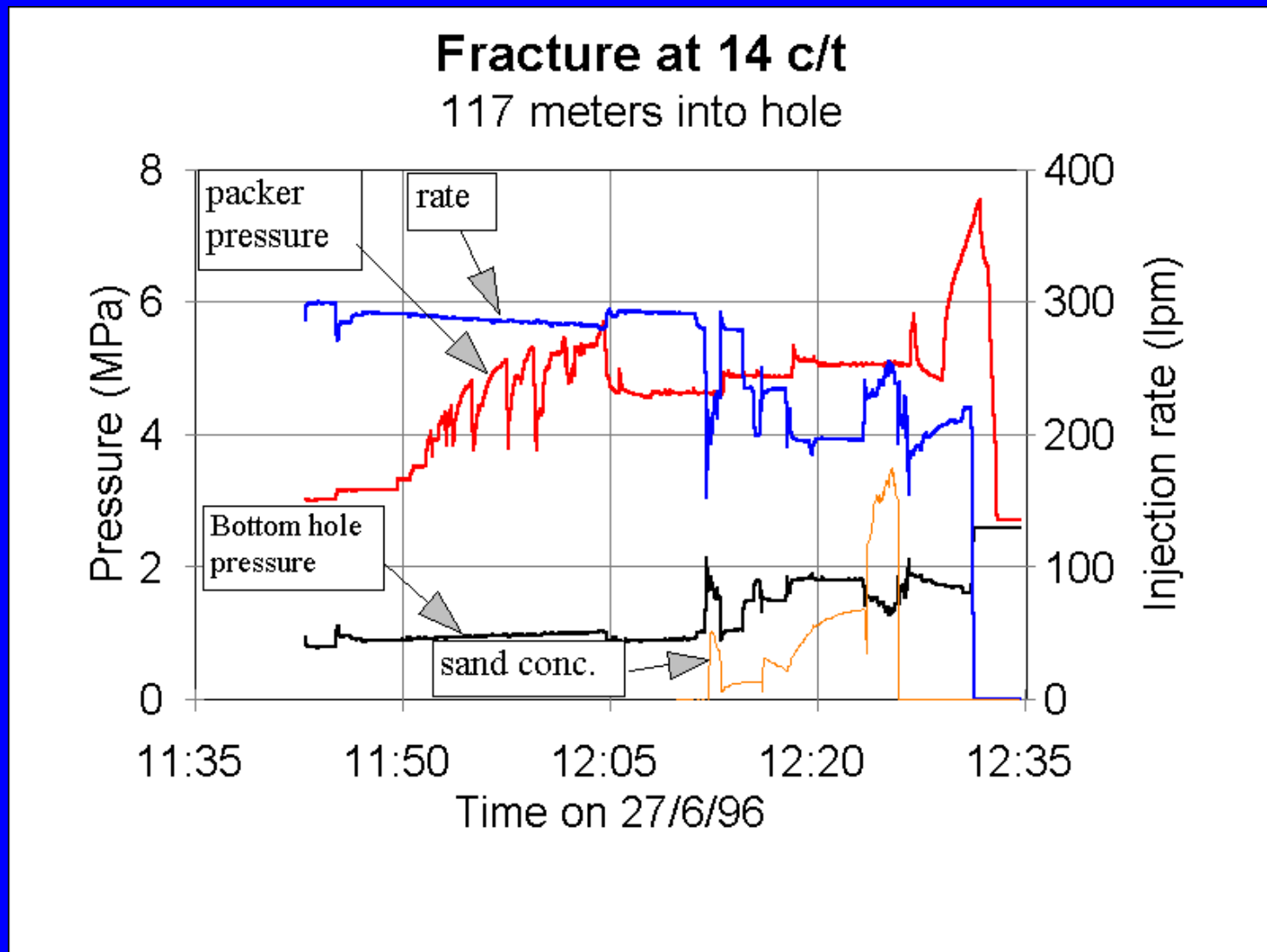

Options

Perforation
(explosive)

cement

Plastic casing

Water jetted
slot

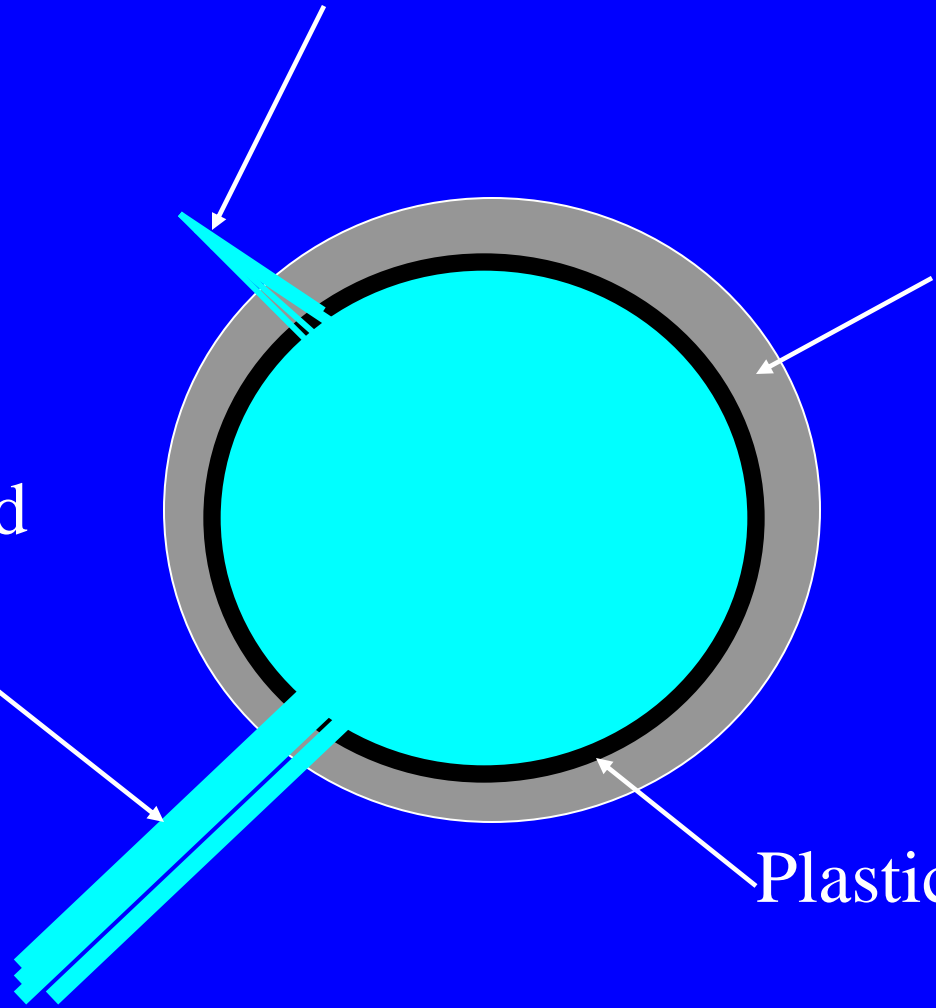

Water jetting of
radial slot.

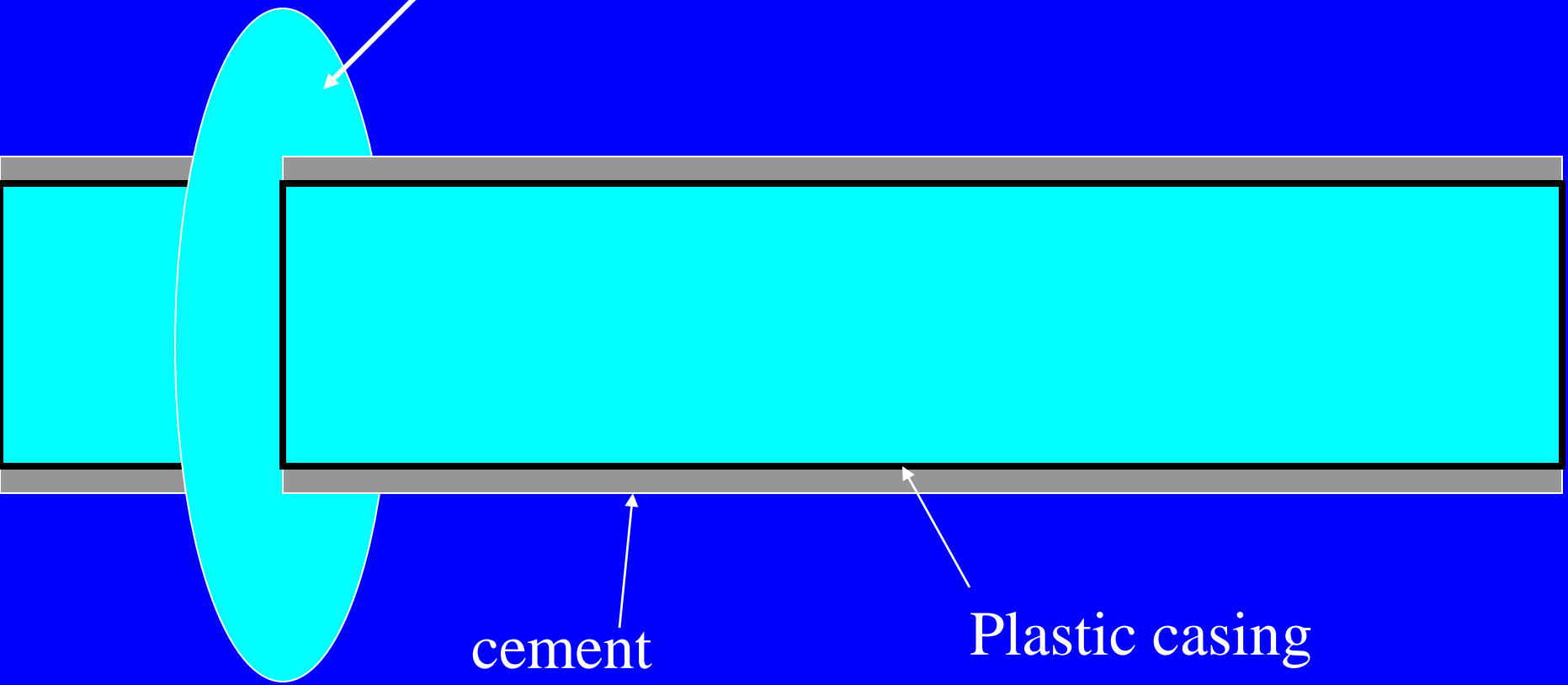

cement

Plastic casing

Conclusions

- A packer seal was not obtained in the horizontal holes and no fracture growth was achieved.
- A seam with more competent coal would allow placement of propped or unpropped fractures.
- A downhole packer inflation tool should be used.
- Other hole completion and fracture placement methods should be tried.